

PLAIN TROLLEYS



ACCOLIFT® Plain Trolleys are light and easy to adapt to a wide range of beams. The trolley wheels include lifetime lubricated ball bearings for maintenance free operation. A perfect match to make the ACCOLIFT® electric or hand chain hoist and its load horizontally mobile.

Construction Features:

Side Frame: Side plates are rugged rolled steel

Wheels: Crown tread allows operation on tapered or flat flange beams

Bearings: Shielded, lifetime lubricated, single row ball bearings.

Suspension Lug: Pivot mounted suspension shaft designed to equally distribute the load to all wheels.

Options: Optional equipment available for this product includes bronze wheels and nickel plated body. Please contact the factory for more information.

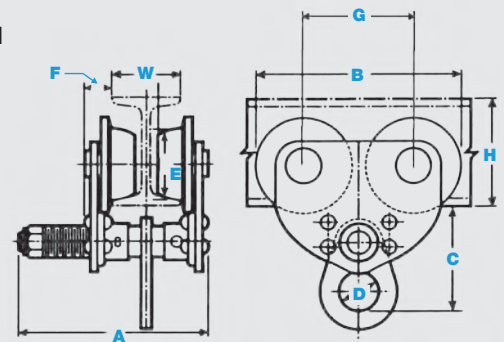

Dimensions in Inches (Nominal)

Model Number	Cap. (Tons)	W Beam Width Min. - Max.	Dimensions								Min. Beam Size H	Min. Beam Radius	Net Weight (lbs.)
			A	B	C	D	E	F	G				
1650010	1/2	3" to 5"	8.1	6.9	5.1	1.8	2.2	1.1	3.5	4	24	14	
1650020	1	3" to 5"	8.1	9.1	5.1	1.8	3.2	1.1	4.8	5	30	22	
1650030	2	3" to 6"	9.3	10.6	6.1	2.4	3.9	1.4	5.6	6	36	41	
1650040	3	3" to 6"	9.9	12.3	7.5	2.6	4.5	1.9	6.4	7	36	63	
1650050	5	5" to 7"	11.1	13.9	9.1	3.0	4.9	2.1	7.2	10	48	97	

GEARED TROLLEYS



ACCOLIFT® Geared Trolleys are light and easy to adapt to a wide range of beams. The trolley wheels include lifetime lubricated ball bearings for maintenance free operation. A perfect match to make the ACCOLIFT® electric or hand chain hoist and its load horizontally mobile for short distances and accurate load positioning.

Construction Features:

Side Frame: Side plates are rugged rolled steel

Wheels: Crown tread allows operation on tapered or flat flange beams

Bearings: Shielded, lifetime lubricated, single row ball bearings.

Hand Chain: Electric welded, close link galvanized coil chain, accurately and uniformly sized to seat properly in handwheel pockets.

Chain Guide: Steel chain guide.

Suspension Lug: Pivot mounted suspension shaft designed to equally distribute the load to all wheels.

Options: Optional equipment available for this product includes bronze wheels, stainless steel hand chain and nickel plated body. Please contact the factory for more information.

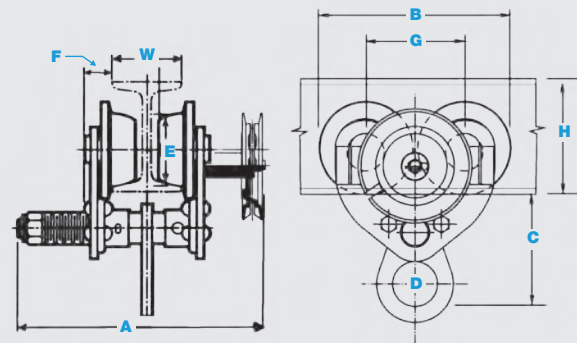

Dimensions in Inches (Nominal)

Model Number	Cap. (Tons)	W Beam Width Min. - Max.	Hand Chain Drop (ft.)	Dimensions								Min. Beam Size H	Min. Beam Radius	Net Weight (lbs.)
				A	B	C	D	E	F	G				
1650110	1/2	3" to 5"	18	10.8	9.1	5.1	1.8	3.2	1.1	4.8	5	30	35	
1650120	1	3" to 5"	18	10.8	9.1	5.1	1.8	3.2	1.1	4.8	5	30	35	
1650130	2	3" to 6"	18	12.0	10.6	6.1	2.4	3.9	1.4	5.6	6	36	57	
1650140	3	3" to 6"	18	13.0	12.3	7.5	2.6	4.5	1.9	6.4	7	36	79	
1650150	5	5" to 7"	18	15.0	13.9	9.1	3.0	4.9	2.1	7.2	10	48	114	
1650160	10	5" to 7.5"	18	17.0	13.9	11.0	3.2	4.9	2.1	7.2	10	48	227	